

**GENERAL NOTES:**

- A. All work, including trenching, backfill, compaction, and testing of materials shall be performed per Project Specifications and as shown on this detail.
- B. After completion of testing, valve shall be closed, temporary blow-off capped and the area resurfaced.
- C. G-5 box in/behind sidewalk to be removed at time of fireline connection to building.

**OTHER NOTES:**

- ① Alternate location where building abuts sidewalk allowed only with written approval of Utilities Department.
- ② Temporary cap shall be removed at the time the service is connected to the fire sprinkler system. USC approved backflow prevention device shall be installed per Engineering Standard #6420.

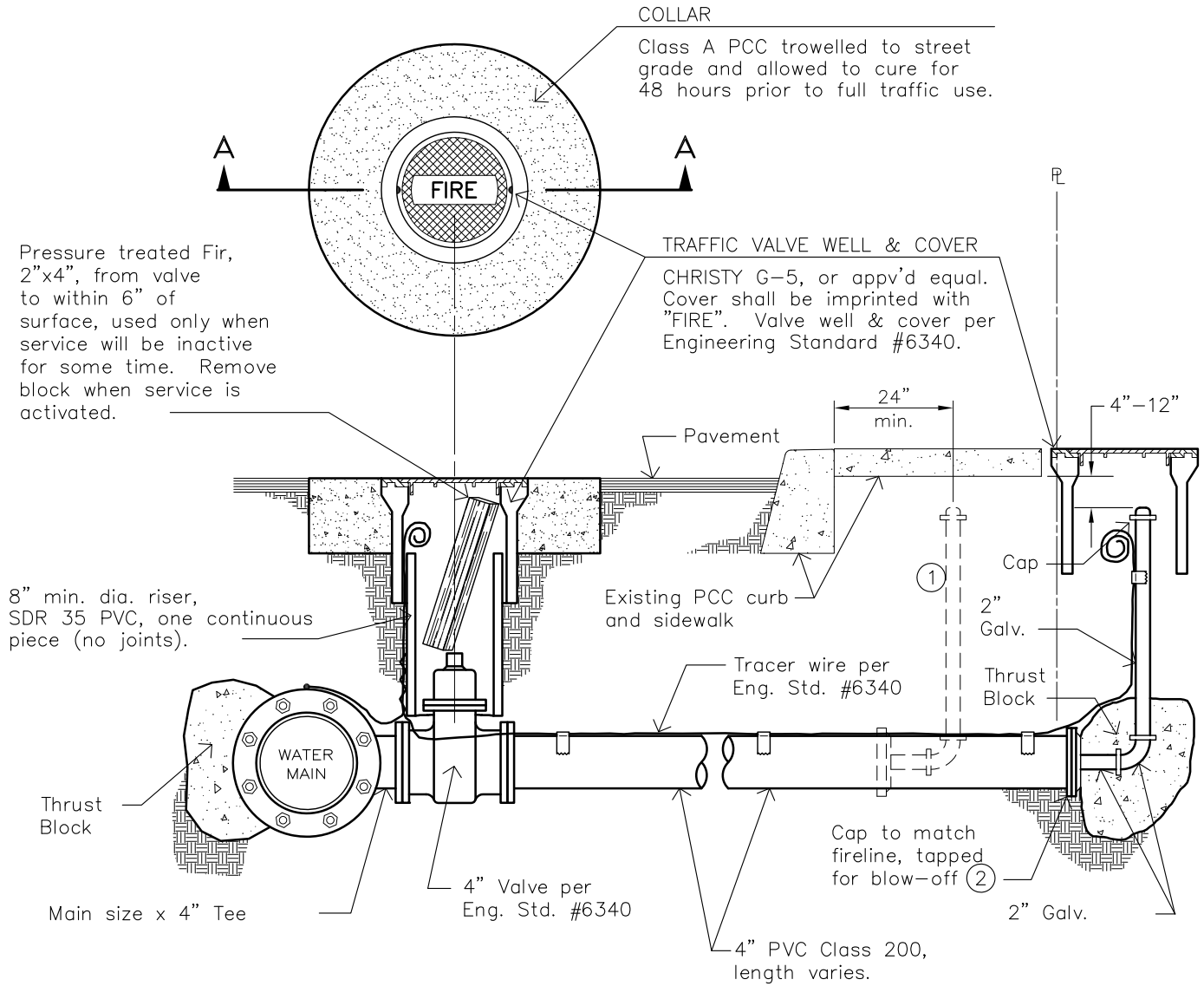

**SECTION A-A**

*THIS DETAIL APPLIES TO NEW FIRE SERVICE ON NEW OR EXISTING WATER MAIN.*

REVISIONS	BY	APP	DATE
Temp G-5 box to BOW	JDL	JDW	1-03
Larger riser	MH	BL	12-08
Add note 2, rem. block	JDL	WAP	4-00
STANDARD CURRENT AS OF:		January 2010	



**NEW FIRE SERVICE  
4"**

6530